



# ECO800™

## VARIABLE SPEED POOL PUMP

The Energy Saver



### FEATURES & BENEFITS

The Onga Eco800 is the ideal pump for new or existing pools. Utilising advanced hydraulic design and the latest technology in permanent magnet, variable speed motors, the Onga Eco800 has the perfect combination of efficiency and performance. The Onga Eco800 delivers energy savings and the power when you need it. You will also have the peace of mind that you are doing your bit for the environment and reducing your carbon foot print.

**V**ariable speed pump, with 3 programmable speeds, allows you to effortlessly select the most efficient setting to meet your filtration, cleaning and water feature needs.

**A**xial flux, brushless, permanent magnet motor delivers high efficiency and low noise levels.

**F**ault protected motor prevents damage by automatically shutting down the motor in the event of a locked rotor, under voltage, over voltage or over current condition and will automatically reduce the speed during an over temperature condition.

**P**recision-fit internal components and superior hydraulic design deliver effortless performance, energy savings and extended pump life.

**A** specially designed sound-dampening pump casing and base make pump operation incredibly quiet.

**T**he Cam and Ramp™ lid is easy to remove and locks in place with a quarter turn, making inspection and cleaning a breeze. The high-capacity trap holds a large amount of debris, so you clean less often.

**C**onstructed of our durable, thermoplastic, composite resin, so you can be sure it will stand up to the harshest conditions.

**A** heavy-duty construction and a motor rated for continuous operation make the Eco800 a tough, long-lasting performer.

**V**ariable Speed with 3 Programmable Settings

**Q**uick-disconnect plumbing unions.

**8** star energy rating.

### TECHNOLOGY

## VARIABLE SPEED WITH 3 PROGRAMMABLE SETTINGS

The Onga Eco800 uses an axial-flux, brushless, DC motor which offers high efficiency levels compared with conventional induction motors. Combined with the latest in electronic control, this allows the motor/pump to run at varying speeds.

- The multiple speeds offered by the Eco800 enable the pump to run slower and consume less energy but still have the ability to run at full speed if required by the application.



### PERFORMANCE

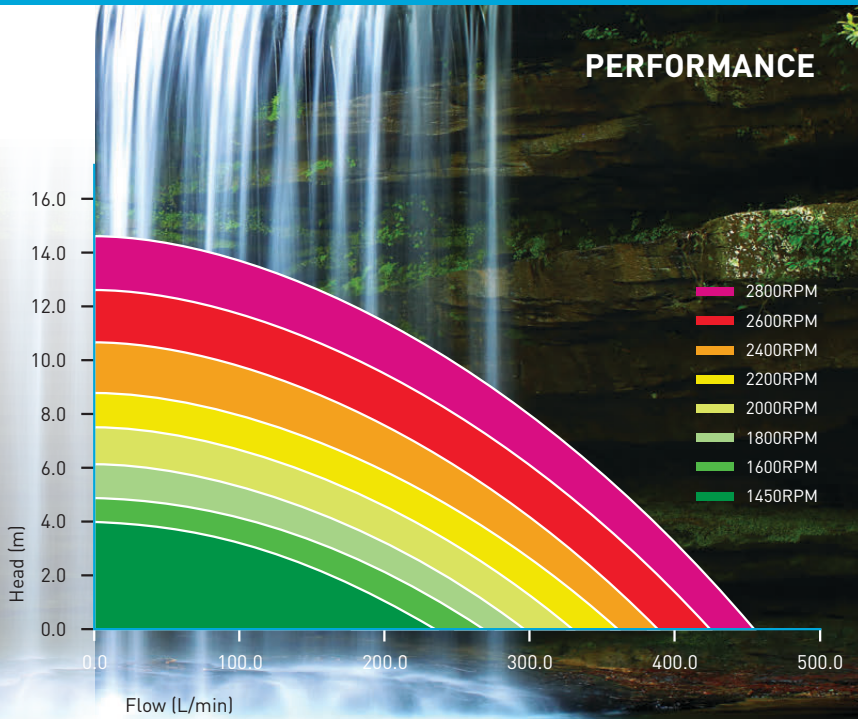



# ECO800™ VARIABLE SPEED POOL PUMP



## PUMP DATA

	Low	Medium	High
RPM*	1450	2400	2800
Motor Input Power (P1) (max)	160W	595W	940W
Motor Output Power (P2) (max)	130W	475W	750W
Current (max)	1.3A	4.4A	6.5A
Sound Power Level (Lwa)	57.5 dB	65.2 dB	69.3 dB
Maximum Rating	2850RPM, P1 975W, P2 800W, 6.7A		
Voltage	230-240VAC 50Hz Single Phase		
Motor type	800W BLDC TEFC		
Ingress Protection	IPX5		
Inlet connection	ABS Barrel Union to suit 50mm PVC pressure pipe		
Outlet Connection	ABS Barrel Union to suit 50mm PVC pressure pipe		
Maximum Water Temperature:	40°C		
Maximum Ambient Temperature:	55°C		

\*Adjustable speed range 1000-2850RPM

## MATERIAL SPECIFICATIONS

Pump Casing	Polypropylene 40% Glass Filled
Impeller	Polyphenylene Ether
Diffuser	Polypropylene 40% Glass Filled
Basket	Polystyrene
Lid	Polycarbonate
Clamp Ring	Polypropylene 20% Glass Filled
Casing O - Ring	Nitrile
Base	Polypropylene
Diffuser O - Ring	Nitrile
Lid O - Ring	Nitrile
Barrel Unions	PVC
Barrel Union O - Ring	Nitrile
Mechanical Seal	¾" Type 6 Carbon - Ceramic, S/S, Nitrile
Motor	Aluminium Alloy
Supply Cord	H07RNF 3G 1mm, 2m
Bearings	6302, 6303

## DIMENSIONS

A	637mm
B	179mm
C	256mm
D	354mm

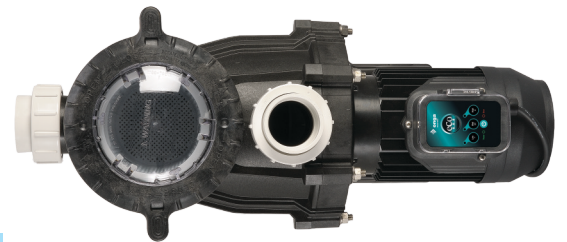
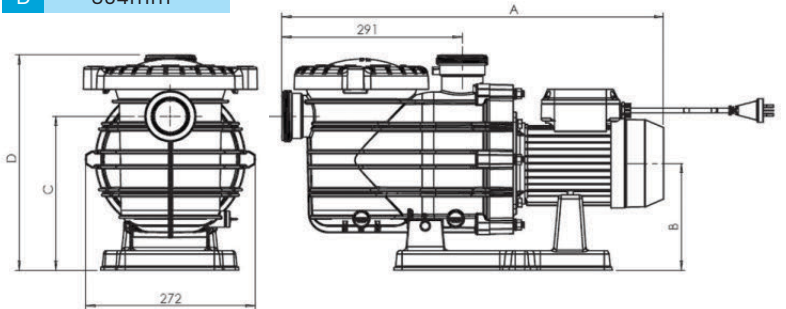

AVAILABLE FROM:



### Head Office

Pentair AU/NZ: 1-21 Monash Drive,  
Dandenong South, Vic 3175

### Australia

National Customer Service: Phone: 1300 137 344  
Fax: 1800 006 688  
National Dealer Locator: Phone: 1800 664 266

Email: [au.sales@pentair.com](mailto:au.sales@pentair.com)  
Web: [www.pentair.com.au](http://www.pentair.com.au)

### New Zealand

National Customer Service: Phone: 0800 654 112  
Fax: 0800 806 642  
National Dealer Locator: Phone: 0800 664 269

Email: [nz.sales@pentair.com](mailto:nz.sales@pentair.com)  
Web: [www.pentair.co.nz](http://www.pentair.co.nz)

### International Australia/New Zealand

Phone: +61 3 9709 5800  
Fax: +61 3 9709 5888

Display, publication, modification or distribution is strictly prohibited without the prior written permission of Pentair Water Pty Ltd.

**Disclaimer:** Every endeavour has been made to publish the correct details in this publication. No responsibility will be taken for errors, omissions or changes in product specifications. Pentair reserves the right to change specifications.

pumps / filters / heaters / heat pumps / automation / lighting / cleaners / sanitizers / water features / maintenance products