



Max e ProTM

POOL PUMP

Strong performer, quiet leader

Max e Pro™

POOL PUMP

Quick-lock, `1/4 turn`, see through lid

Stainless steel motor shaft

50mm quick-connect barrel unions

6" extra large capacity trap

Elevated, sound dampening motor base

Exclusive Dura-Glas™ composite resin

FEATURES & BENEFITS

Nothing but the best

Pentair's reputation for top-of-the-line equipment is unparalleled in the industry. Every feature of the Max-e-Pro has been engineered to answer the needs of today's savvy buyer: high efficiency, low maintenance and reliability. The Max-e-Pro nails it on all counts.

A lot less maintenance

When cleaning is required, an easy twist of the wrist gives you access to the ultra-sized strainer basket. Simply empty the basket, re-attach the Quick-Lock™ trap lid and twist it one click to the right.

Quiet heavy duty motor

Reliability and quality are integral benefits of this continuously rated motor. Low noise levels result in peaceful pump operation.

Precision-fit internal components

And a specially designed sound-dampening base make the MAXePRO™ extremely quiet. So your piece of paradise remains peaceful.

Built for the long-run

Only the finest materials are used to build lasting quality into every maxepro. On the outside, Pentair's exclusive Dura-Glas™ composite resin weathers temperature extremes. On the inside, the shaft and seal are constructed with Stainless steel and the impeller is made with Noryl® to stand tough against harsh chemicals.

50mm barrel unions

Quick and easy to install, creating a perfect seal while allowing pump removal without flexing pipework.

Electrical approvals

Rest easy knowing your Pantera pool pump has passed the Australian Standard AS/NZS 60335.2.41 for safety and is approved for installation within the wetted zone of the pool area.



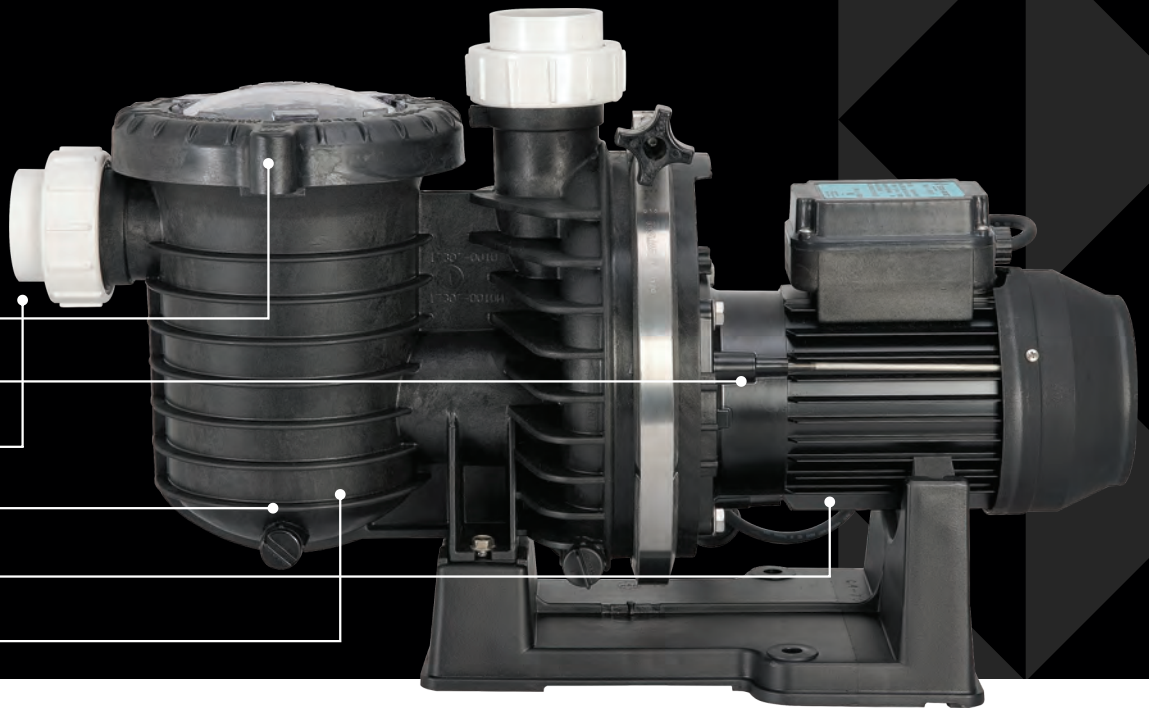

PUMP PERFORMANCE CHART

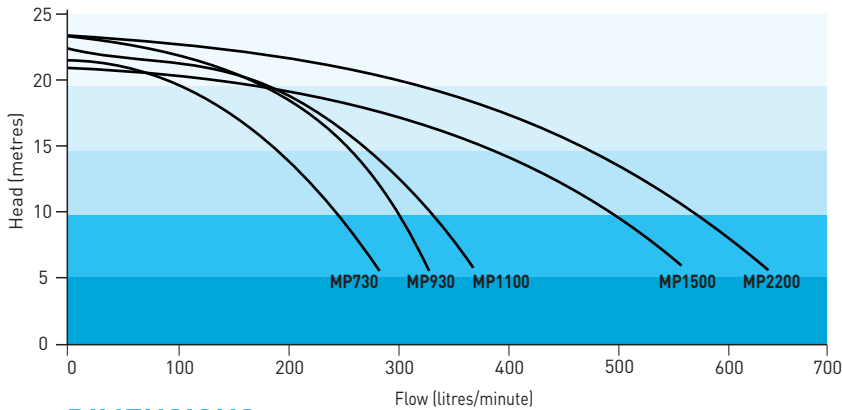

DIMENSIONS

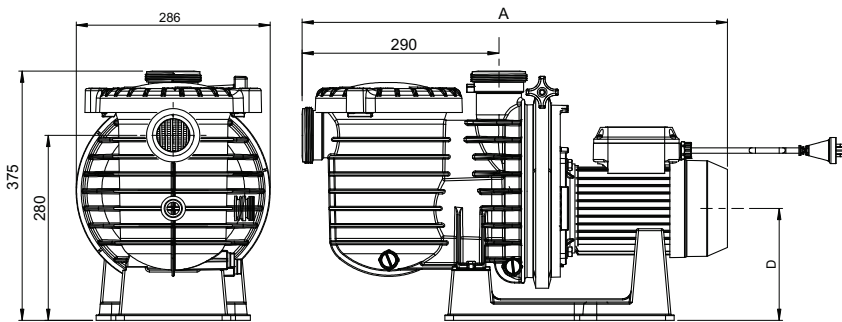

Pump Model	MP730100	MP930100	MP1100100	MP1108100	MP1500100	MP1508100	MP2200100	MP2208100
A (mm)	629	650	650	696	690	721	694	721
D (mm)	165	171	171	187	171	187	181	187

MODEL DATA

Pump Model	Power (w) Input (P1)	Power (w) Output (P2)	Supply Voltage	Phase	Full Load Current (A)	Locked Rotor Current (A)	Capacitor µfd	Supply Cord Length (m)	Net Weight (kg)	Packed Weight (kg)	Carton Dimensions (LxWxH)
MP730100	925	690	230	1	4.1	14	25	2	14.5	16.5	725x325x390
MP930100	1160	870	230	1	5.4	22	25	2	17.5	19.5	725x325x390
MP1100100	1330	1000	230	1	6.0	22	25	2	17.5	19.5	725x325x390
MP1108100	1250	1000	400	3	2.7	23	-	-	26	28	725x325x390
MP1500100	1800	1350	230	1	7.9	28	35	2	20.5	22.5	725x325x390
MP1508100	1750	1350	400	3	3.0	23	-	-	26	28	725x325x390
MP2200100	2435	1950	230	1	10.7	42	2x25	2	25.5	27.5	725x325x390
MP2208100	2420	1980	400	3	4.4	38	-	-	28	30	725x325x390

OPERATING CONDITIONS

Suitable for pumping clean non-aggressive liquids without solids or fibres in suspension.

Fluid:	Water
Maximum working pressure:	360 kPa
Water (Swim Pool) temp range:	5°C-40°C
Ambient temperature:	55°C maximum

MOTOR

Type:	TEFC 2 pole continuously rated
Nominal speed:	2900 rpm
IP rating:	IP55
Insulation class:	Class F
Thermal overload:	Internal, auto reset
Frequency:	50Hz
Voltage:	230-240V Single phase 400-415V 3 phase
Bearing type:	Deep groove ball bearing (with double contact lip seal)

MATERIALS

Component	Material
Pump Casing	30% Glass Filled Polypropylene
Impeller	30% Glass Filled Polypropylene
Baffle	40% TF Polypropylene
Diffuser	20% Glass Filled ABS
Yoke	20% Glass Filled ABS
Drain Plug	Polypropylene
Shaft Sleeve	20% Glass Filled Polycarbonate
Motor Shaf	303 Stainless Steel
End Shield	Enamel Painted Aluminium
Hair & Lint Pot O-Ring	Low Friction Nitrile
Hair & Lint Pot Lid	Polycarbonate
Casing O-Ring	Nitrile
Barrel Union O-Ring	Nitrile
Barrel Union	ABS

Max e Pro™

POOL PUMP

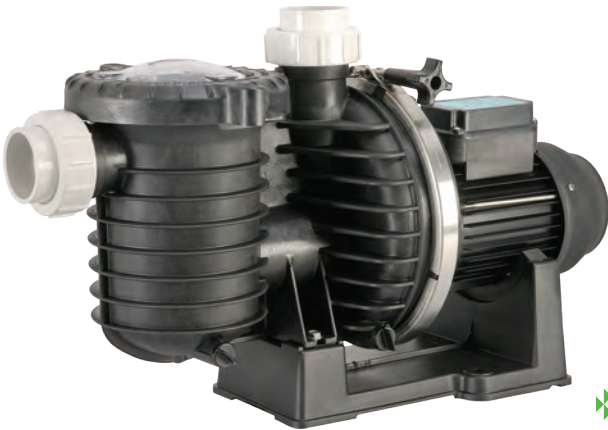

AVAILABLE FROM:

Head Office

Pentair AU/NZ: 1-21 Monash Drive,
Dandenong South, Vic 3175

Australia

National Customer Service: Phone: 1300 137 344
Fax: 1800 006 688
National Dealer Locator: Phone: 1800 664 266

Email: au.sales@pentair.com
Web: www.pentair.com.au

New Zealand

National Customer Service: Phone: 0800 654 112
Fax: 0800 806 642
National Dealer Locator: Phone: 0800 664 269

Email: nz.sales@pentair.com
Web: www.pentair.co.nz

International Australia/New Zealand

Phone: +61 3 9709 5800
Fax: +61 3 9709 5888

Display, publication, modification or distribution is strictly prohibited without the prior written permission of Pentair Water Pty Ltd.

Disclaimer: Every endeavour has been made to publish the correct details in this publication. No responsibility will be taken for errors, omissions or changes in product specifications. Pentair reserves the right to change specifications.

pumps / filters / heaters / heat pumps / automation / lighting / cleaners / sanitizers / water features / maintenance products